

FLUORESCENT

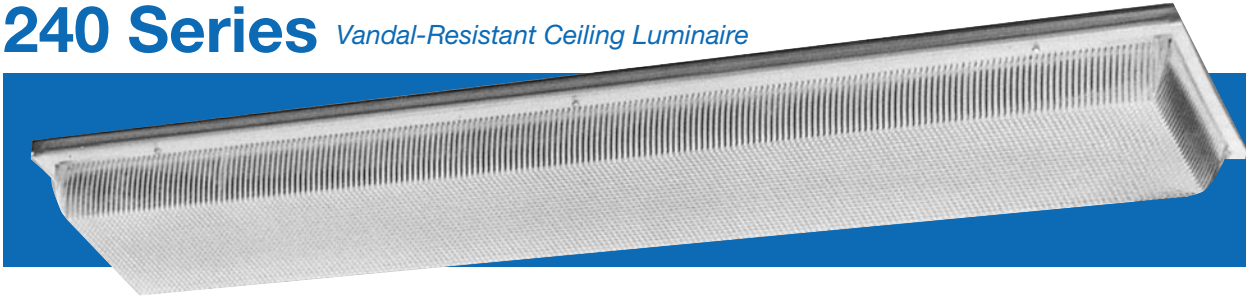

240 Series *Vandal-Resistant Ceiling Luminaire*



This fluorescent luminaire with standard electronic ballast combines optimal light distribution and energy efficiency with impact resistance in an aesthetically attractive design. Optional emergency battery system eliminates the need for special-purpose lighting. For indoor and protected outdoor uses, this luminaire is perfect for schools, hospitals, prisons; and public, commercial, and government buildings.

Specifications

Lens:	Pressure formed of clear UV-stabilized polycarbonate in average $\frac{1}{8}$ " thickness. Clear lens is enhanced with prisms engineered for maximum light control.
Base Plate:	Die formed of 20-gauge steel or aluminum with high-reflectance white baked enamel finish applied after forming . Options: 16-gauge steel housing — consult factory for availability.
Gasket:	Concealed polyethylene gasket is bonded to lens to create a tight seal against contaminants and moisture.
Wireway:	Tool-less tab attachment facilitates installation and removal of wireway channel.
Ballast:	Electronic, thermally protected Class P, energy-saving, High Power Factor ballast for 120V-277V. 32-FL-T8 Instant-start 0°F (-18°C).
Wet Location:	Covered Ceiling
Lamps: (Optional)	Uses two 32FLT8.
Emergency Battery Pack: (Optional)	Nickel cadmium battery is maintenance free with a life of 7-10 years and a 90-minute emergency operating time. Battery is charging during normal operations of fixture. During power interruption, lamp will switch to emergency operation. When A.C. power is restored, lamp is switched back to the ballast and the battery is recharged within 24 hours. Note: Can be wired to operate only during power interruption. (See Emergency Fixture Information Sheet, Form 1568).
Conduit Housing: (Optional)	Die formed of 16-gauge steel with baked enamel white finish. Knockout for $\frac{1}{2}$ " conduit on each end and six mounting holes is limitedly available — consult factory for availability.
Corner Bracket: (Optional)	Die formed of 20-gauge steel with baked enamel white finish — consult factory for availability.
Hardware:	Six stainless steel philips head screws or optional tamprproof screws are provided for lens attachment. Mounting hardware provided by others.

Dimensions

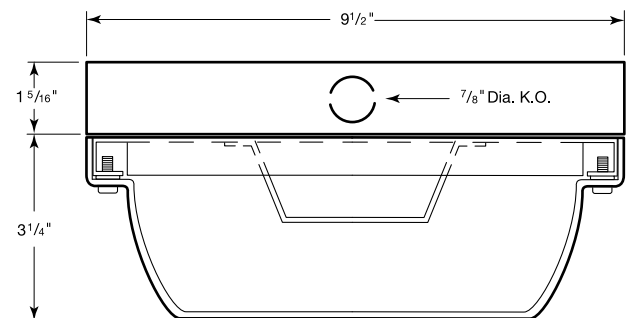

Shown With Optional Conduit Housing

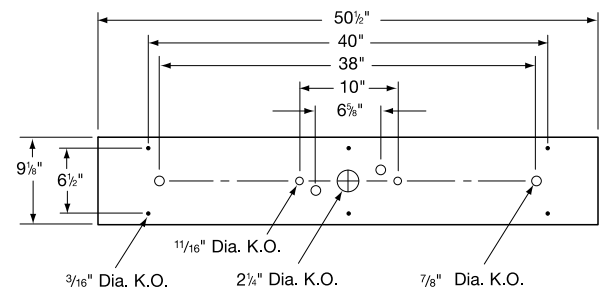

Base Plate Hole Pattern



**SBA QUALIFIED
SMALL BUSINESS MANUFACTURER**

TAA COMPLIANT
TRADE AGREEMENT ACT COMPLIANT

ETL-US and ETL-C Listed For Damp Location Covered Ceiling

All polycarbonate components meet Underwriters Laboratories 746C tests for polymeric material and carry a flammability rating of 94HB or better on lenses and the superior 94-5V rating on housings.

Luminaire Type _____
 Catalog Number _____
 Job Name _____
 Approval _____

W_FHarris Lighting, Inc.™

Innovative Lighting Designs Since 1970

P.O. Box 5023, Monroe, NC 28111-5023, USA
 704.283.7477 (HEADQUARTERS) • 800.842.9345 (TOLL FREE)
 e-mail: customerservice@wfharris.com
 www.wfharrislighting.com

Form 1536

5/19

"A Live Operator Company Standing Ready to Serve Your Lighting Needs"

FLUORESCENT

Ordering Information (Fill In Blocks For Complete Catalog Number)

			HPF			
Model 240	Lens CP- Clear Prismatic	Watts-Lamp 2-32FLT8	Power Factor HPF	Volts 120—277	Options	Installation Wet Location Wet Location Covered Ceiling

Accessories (Order Separately)
TPT-Tamperproof Screwdriver



- EM-** Emergency Battery Pack with One Lamp Operating During Normal Conditions and One Lamp Operating During Emergency
- EM01-** Emergency Battery Pack with One Lamp Operating During Normal Conditions; One Lamp Operating During Emergency
- EM2-** Emergency Battery Pack with Both Lamps Operating During Normal Conditions; Both Lamps Operating During Emergency
- EMO2-** Emergency Mode Only for Both Lamps
- WLO-240-** Wet Location Outside Gasket (Must Specify Application) (Not required for covered ceiling application)
- FS-** Fuse and Holder
- FNL-120 -** 9W PL Night Light Ballast/Socket Only (Second Ballast is 120V Only)
- FNLP-120 -** 9W PL Night Light With Lamp (Second Ballast is 120V Only)
- 240B-** 16 Gauge Steel Conduit Box (Consult factory)
- 240C-** 16 Gauge Steel Corner Mounting Bracket (Consult factory)
- TPS-** Stainless Steel Tamperproof Screws
- LS -** Slotted Head Screws
- LP-** Two Lamps (F32T8, TL835, 3500K, BiPin, 2-Pin on each end)

Photometric Data

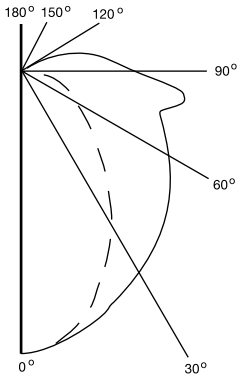

COEFFICIENTS OF UTILIZATION - ZONAL CAVITY METHOD
EFFECTIVE FLOOR CAVITY REFLECTANCE 0.20

RC	80				70				50			30			10			0
RW	70	50	30	10	70	50	30	10	50	30	10	50	30	10	50	30	10	0
0	57	57	57	57	56	56	56	56	52	52	52	49	49	49	46	46	46	44
1	52	49	46	44	50	47	45	43	44	42	41	41	40	39	39	38	36	35
2	47	42	39	36	45	41	38	35	38	36	33	36	34	32	34	32	30	29
3	43	37	33	30	41	36	32	29	34	31	28	32	29	27	30	28	26	25
4	39	33	29	25	38	32	28	25	30	27	24	28	26	23	27	24	22	21
5	36	29	25	22	34	29	24	21	27	23	20	25	22	20	24	21	19	18
6	33	26	22	19	32	26	21	18	24	21	18	23	20	17	22	19	17	16
7	31	24	19	16	29	23	19	16	22	18	16	21	18	15	20	17	15	14
8	28	21	17	14	27	21	17	14	20	16	14	19	16	13	18	15	13	12
9	26	19	15	12	25	19	15	12	18	14	12	17	14	12	16	13	11	10
10	24	18	14	11	23	17	13	11	16	13	11	16	13	10	15	12	10	9



**SBA QUALIFIED
SMALL BUSINESS MANUFACTURER**
TAA COMPLIANT
TRADE AGREEMENT ACT COMPLIANT

W.F. Harris Lighting, Inc.™

Innovative Lighting Designs Since 1970

P.O. Box 5023, Monroe, NC 28111-5023, USA

704.283.7477 (HEADQUARTERS) • 800.842.9345 (TOLL FREE)

e-mail: customerservice@wfharris.com

www.wfharrislighting.com

Specifications Subject to Change Without Notice

Luminaire is Warranted to be Free of Defects in Materials and Workmanship for One Year From Invoice Date.

Printed in USA

Form 1536

5/19

“W. F. Harris Lighting Will Not Sacrifice Quality for the Sake of Price.”